

# Sample Exam – Answers

Sample Exam set B  
Version 1.3

## ISTQB® Certified Tester Syllabus Foundation Level

Compatible with Syllabus version 2018 v3.1

---

International Software Testing Qualifications Board

---

The logo for the International Software Testing Qualifications Board (ISTQB). It features the acronym "ISTQB" in a bold, blue, sans-serif font. A red swoosh, resembling a stylized checkmark or a curved line, arches over the letters "I" and "S", and another smaller red swoosh is positioned below the "B".

ISTQB®

Release Date: March 17, 2020

Copyright Notice

This document may be copied in its entirety, or extracts made, if the source is acknowledged.

## Legal

Copyright © 2019 International Software Testing Qualifications Board (hereinafter called ISTQB®). All rights reserved.

The authors transfer the copyright to the International Software Testing Qualifications Board (hereinafter called ISTQB®). The authors (as current copyright holders) and ISTQB® (as the future copyright holder) have agreed to the following condition of use:

Any ISTQB® Member Board may translate this document.

Exam Working Group 2020

## Document Responsibility

The ISTQB® Examination Working Group is responsible for this document.

## Acknowledgements

This document was produced by a core team from the ISTQB®: Foundation Working Group

The core team thanks the Exam Working Group review team, the Syllabus Working Group and the National Boards for their suggestions and input.

This document is maintained by a core team from ISTQB® Exam Working Group.

## Revision History

Sample Exam – Answers Layout Template used: Version 2.0 Date: Marts 16, 2020

Version	Date	Remarks
1.0	May 11, 2018	First version
1.1	February 29, 2019	Refactor layout on Sample Exam Template Minor changes to Answers: 14, 20, 32, 34, 35, 37
1.2	December 30, 2019	Minor changes to Answers: 2, 8, 11 Major changes to Answers: 10, 23, 28 Replaced Answer: 15
1.3	March 17, 2020	Transfer to new Sample Exam Template layout Minor changes to Answers: 15,16, 23, 24 Major changes to Answers: 1, 2

# Table of Contents

Legal.....	2
Document Responsibility .....	2
Acknowledgements.....	2
Revision History .....	3
Table of Contents.....	4
Introduction.....	5
Purpose of this document.....	5
Instructions.....	5
Answer Key.....	6
Answers.....	7
1.....	7
2.....	7
3.....	7
4.....	7
5.....	8
6.....	8
7.....	9
8.....	9
9.....	10
10.....	11
11.....	12
12.....	12
13.....	13
14.....	13
15.....	14
16.....	14
17.....	15
18.....	16
19.....	16
20.....	17
21.....	18
22.....	19
23.....	20
24.....	20
25.....	21
26.....	22
27.....	22
28.....	23
29.....	24
30.....	24
31.....	25
32.....	25
33.....	26
34.....	26
35.....	27
36.....	27
37.....	28
38.....	29
39.....	30
40.....	30

## Introduction

### Purpose of this document

The sample questions and answers and associated justifications in this sample exam set have been created by a team of Subject Matter Experts and experienced question writers with the aim of assisting ISTQB® Member Boards and Exam Boards in their question writing activities.

These questions cannot be used as-is in any official examination, but they should serve as guidance for question writers. Given the wide variety of formats and subjects, these sample questions should offer many ideas for the individual Member Boards on how to create good questions and appropriate answer sets for their examinations.

### Instructions

The answer set is organized in the following way:

- Correct answer – including justification of the answers
- Learning Objective and K-level of Questions
- Answer Key with Learning Objective and K-level for each question
  
- Questions are contained in a separate document

## Answer Key

Question Number (#)	Correct Answer	LO	K-Level	Points
1	b	Keywords	K1	1
2	a	FL-1.1.1	K1	1
3	c	FL-1.2.3	K2	1
4	c	FL-1.2.4	K2	1
5	d	FL-1.3.1	K2	1
6	a	FL-1.4.2	K2	1
7	b	FL-1.4.4	K2	1
8	b	FL-1.5.2	K2	1
9	d	FL-2.1.1	K2	1
10	a	FL-2.2.1	K2	1
11	c	FL-2.3.2	K1	1
12	b	FL-2.3.3	K2	1
13	a	FL-2.4.2	K2	1
14	d	FL-3.1.2	K2	1
15	d	FL-3.2.1	K2	1
16	a	FL-3.2.2	K1	1
17	b	FL-3.2.3	K2	1
18	b	FL-3.2.4	K3	1
19	b	Keywords	K1	1
20	a	FL-4.1.1	K2	1

Question Number (#)	Correct Answer	LO	K-Level	Points
21	d	FL-4.2.1	K3	1
22	b	FL-4.2.1	K3	1
23	c	FL-4.2.2	K3	1
24	c	FL-4.2.3	K3	1
25	d	FL-4.2.4	K3	1
26	a	FL-4.2.5	K2	1
27	b	FL-4.3.1	K2	1
28	d	FL-4.3.2	K2	1
29	c	FL-4.4.1	K2	1
30	d	FL-5.1.1	K2	1
31	a	FL-5.1.2	K1	1
32	d	FL-5.2.3	K2	1
33	b	FL-5.2.4	K3	1
34	c	FL-5.2.6	K2	1
35	c	FL-5.5.1	K1	1
36	a	FL-5.5.2	K2	1
37	b	FL-5.5.3	K2	1
38	d	FL-5.6.1	K3	1
39	c	FL-6.1.1	K2	1
40	a	FL-6.2.2	K1	1

## Answers

Question Number (#)	Correct Answer	Explanation / Rationale	Learning Objective (LO)	K-Level	Number of Points
1	b	a) Is not correct. Based on definition of equivalence partition b) Is correct. Based on definition from Glossary c) Is not correct. Based on Glossary definition of testware d) Is not correct. Based on definition of test oracle	Keywords	K1	1
2	a	a) Is correct. One of the major objectives of testing b) Is not correct. Validation of the project plan would be a project management activity c) Is not correct. Contradiction to principle #2; complete/exhaustive testing is not possible d) Is not correct. "Comparing actual results with expected results" is a test performing activity, but not a test objective	FL-1.1.1	K1	1
3	c	a) Is not correct. This is an example of a mistake made by the developer b) Is not correct. This is an example of a defect (something wrong in the code that may cause a failure) c) Is correct. This is a deviation from the expected functionality - a cruise control system should not be affected by the radio d) Is not correct. This is an example of a defect (something wrong in a specification that may cause a failure if subsequently implemented)	FL-1.2.3	K2	1
4	c	a) Is not correct. The lack of familiarity of the requirements author with the fitness domain is a root cause b) Is not correct. The lack of training of the tester in state transition testing was one of the root causes of the defect (the developer presumably created the defect, as well) c) Is correct. The incorrect configuration data represents faulty software in the fitness tracker (a defect), that may cause failures d) Is not correct. The lack of experience in designing user interfaces for wearable devices is a typical example of a root cause of a defect	FL-1.2.4	K2	1

Question Number (#)	Correct Answer	Explanation / Rationale	Learning Objective (LO)	K-Level	Number of Points
5	d	a) Is not correct. 'Beware of the pesticide paradox' is concerned with re-running the same tests and their fault-finding effectiveness decreasing b) Is not correct. This testing principle is concerned with performing testing differently based on the context (e.g. games vs safety-critical) c) Is not correct. This testing principle is concerned with the difference between a tested and fixed system and a validated system. No 'errors' does not mean the system is fit for use d) Is correct. If clusters of defects are identified (areas of the system containing more defects than average), then testing effort should be focused on these areas	FL-1.3.1	K2	1
6	a	The correct pairing of test activities and tasks is:  A. Test design – (2) Identifying test data to support the test cases B. Test implementation – (3) Prioritizing test procedures and creating test data C. Test execution – (4) Analyzing discrepancies to determine their cause D. Test completion – (1) Entering change requests for open defect reports  Thus, option a) is correct.	FL-1.4.2	K2	1



Question Number (#)	Correct Answer	Explanation / Rationale	Learning Objective (LO)	K-Level	Number of Points
7	b	a) Is not correct. Traceability will allow existing test cases to be linked with updated and deleted requirements (although there is no support for new requirements), but it will not help with the automation of maintenance testing b) Is correct. If all test cases are linked with requirements, then whenever a new test case (with traceability) is added, it is possible to see if any previously uncovered requirements are covered by the new test case c) Is not correct. Traceability between the test basis and test artifacts will not provide information on which testers found high-severity defects, and, even if this information could be determined, it would be of limited value d) Is not correct. Traceability can help with identifying test cases affected by changes, however areas impacted by side-effects would be the focus of regression testing	FL-1.4.4	K2	1
8	b	a) Is not correct. Both developers and testers gain from experience b) Is correct. Developers are often more interested in designing and building solutions than in contemplating what might be wrong with those solutions c) Is not correct. Both developers and testers should be able to communicate well d) Is not correct. Both developers and testers need to pay attention to detail	FL-1.5.2	K2	1

Question Number (#)	Correct Answer	Explanation / Rationale	Learning Objective (LO)	K-Level	Number of Points
9	d	Considering each statement: <ol style="list-style-type: none"> <li>1. Each development activity should have a corresponding testing activity. TRUE</li> <li>2. Reviewing should start as soon as final versions of documents become available. FALSE – it should start as soon as drafts are available</li> <li>3. The design and implementation of tests should start during the corresponding development activity. FALSE – the analysis and design of tests should start during the corresponding development activity, not the implementation</li> <li>4. Testing activities should start in the early stages of the software development lifecycle. TRUE</li> </ol> Thus, option d) is correct.	FL-2.1.1	K2	1

Question Number (#)	Correct Answer	Explanation / Rationale	Learning Objective (LO)	K-Level	Number of Points
10	a	<p>Considering the scenario:</p> <ol style="list-style-type: none"> <li>1. 'testing is based on interface specifications' – the test basis for integration testing includes interface specifications (along with communication protocol specification), while these are not included for any of the other test levels</li> <li>2. 'testing is focused on finding failures in communication' - failures in the communication between tested components is included as a typical failure for integration testing, but failures in communication is not included for any of the other test levels</li> <li>3. 'the test approach uses both functional and structural test types' - functional and structural test types are both included as possible approaches for integration testing, and would also be appropriate for any of the other test levels, although they are only otherwise explicitly mentioned in the syllabus for system testing</li> </ol> <p>Thus, option a) is correct.</p>	FL-2.2.1	K2	1

Question Number (#)	Correct Answer	Explanation / Rationale	Learning Objective (LO)	K-Level	Number of Points
11	c	<p>a) Is not correct. It is possible to perform any of the test types (functional, non-functional, white-box) at any test level - so, although it is correct that functional and non-functional testing can be performed at system and acceptance test levels, it is incorrect to state that white-box testing is restricted to component and integration testing</p> <p>b) Is not correct. It is possible to perform any of the test types (functional, non-functional, white-box) at any test level - so, it is incorrect to state that white-box testing is restricted to component testing</p> <p>c) Is correct. It is possible to perform any of the test types (functional, non-functional, white-box) at any test level</p> <p>d) Is not correct. It is possible to perform any of the test types (functional, non-functional, white-box) at any test level - so, it is incorrect to state that white-box testing is restricted to component testing and integration testing</p>	FL-2.3.2	K1	1
12	b	<p>a) Is not correct. Although the description of regression testing is largely correct, the description of confirmation testing (which should be testing a defect has been fixed) is not correct</p> <p>b) Is correct. The descriptions of both confirmation and regression testing match the intent of those in the syllabus</p> <p>c) Is not correct. Although the description of regression testing is largely correct, the description of confirmation testing (re-running all previously run tests to get the same results) is not correct, as the purpose of confirmation testing is to check that tests that previously failed now pass (the fix worked)</p> <p>d) Is not correct. Although the description of confirmation testing is largely correct, the description of regression testing (re-running tests that previously failed) is not correct (this is a more detailed description of confirmation testing)</p>	FL-2.3.3	K2	1

Question Number (#)	Correct Answer	Explanation / Rationale	Learning Objective (LO)	K-Level	Number of Points
13	a	<p>a) Is correct. Impact analysis may be used to identify those areas of the system that will be affected by the fix, and so the extent of the impact (e.g. necessary regression testing) can be used when deciding if the change is worthwhile</p> <p>b) Is not correct. Although testing migrated data is part of maintenance testing (see conversion testing), impact analysis does not identify how this is done</p> <p>c) Is not correct. Impact analysis shows which parts of a system are affected by a change, so it can show the difference between different hot fixes in terms of the impact on the system, however it does not give any indication of the value of the changes to the user</p> <p>d) Is not correct. Impact analysis shows which parts of a system are affected by a change; it cannot provide an indication of the effectiveness of test cases</p>	FL-2.4.2	K2	1
14	d	<p>a) Is not correct. Reviews should increase the quality of specifications, however the time required for development and testing should decrease</p> <p>b) Is not correct. Detecting defects is generally easier earlier in the lifecycle</p> <p>c) Is not correct. Reviews will result in fewer missed requirements and better communication between testers and developers, however this is not true for static analysis</p> <p>d) Is correct. This is a benefit of static analysis</p>	FL-3.1.2	K2	1

Question Number (#)	Correct Answer	Explanation / Rationale	Learning Objective (LO)	K-Level	Number of Points
15	d	<p>a) Is not correct. During planning it is decided whether checklists are used. The preparation of the checklists is not part of the planning. In addition, the reviewers are neither involved in the planning, nor responsible for the creation of the checklists</p> <p>b) Is not correct. During issue communication, any potential defects that have been identified in the individual review are communicated. The completion of checklists by the reviewers already takes place, if at all, during individual review</p> <p>c) Is not correct. During review session, the reviewers communicate any potential defects of the work product that they did identify during the individual review. Defect reports are only created during the fixing and reporting activity</p> <p>d) Is correct. Initiating the review (“Kick-off”) involves distributing the work product and other materials, like checklists</p>	FL-3.2.1	K2	1
16	a	<p>a) Is correct. The management decides about performing the review</p> <p>b) Is not correct. The moderator, not the review leader should ensure the effective running of review meetings</p> <p>c) Is not correct. The author fixes the work product under review</p> <p>d) Is not correct. The manager monitors ongoing cost-effectiveness</p>	FL-3.2.2	K1	1

Question Number (#)	Correct Answer	Explanation / Rationale	Learning Objective (LO)	K-Level	Number of Points
17	b	<p>Considering the attributes:</p> <ul style="list-style-type: none"> <li>• There is a role of a scribe – specified for walkthroughs, technical reviews and inspections; thus, the reviews being performed cannot be informal reviews</li> <li>• The purpose is to detect potential defects – the purpose of detecting potential defects is specified for all types of review.</li> <li>• The review meeting is led by the author – this is not allowed for inspections and is typically not the author for technical reviews, but is part of walkthroughs, and allowed for informal reviews</li> <li>• Reviewers find potential issues by individual review - all types of reviews can include individual review (even informal reviews)</li> <li>• A review report is produced - all types of reviews can produce a review report, although it would be less likely for an informal review</li> </ul> <p>Thus, option b) is correct.</p>	FL-3.2.3	K2	1

Question Number (#)	Correct Answer	Explanation / Rationale	Learning Objective (LO)	K-Level	Number of Points
18	b	<p>Considering the potential inconsistencies:</p> <ul style="list-style-type: none"> <li>• 6-10 – If librarians should get system responses within 5 seconds, it is NOT inconsistent for borrowers to get system responses within 3 seconds.</li> <li>• 6-15 - If librarians should get system responses within 5 seconds, it is inconsistent for all users to get system responses within 3 seconds.</li> <li>• 7-12 – If borrowers can borrow a maximum of 3 books at one time it is NOT inconsistent for them to also reserve books (if they are on-loan).</li> <li>• 9-11 – If a borrower can be fined for failing to return a book within 3 weeks it is inconsistent for them to also be allowed to borrow a book at no cost for a maximum of 4 weeks – as the length of valid loans are different.</li> </ul> <p>Thus, of the potential inconsistencies, 6-15 and 9-11 are valid inconsistencies, and so option b) is correct.</p>	FL-3.2.4	K3	1
19	b	<p>a) Is not correct. Exploratory testing is often carried out when timescales are short, so making in-depth investigations of the background of the test object is unlikely</p> <p>b) Is correct. Glossary definition</p> <p>c) Is not correct. Based on the Glossary definition of session-based testing, but with test execution replaced by test analysis</p> <p>d) Is not correct. Glossary definition of experience-based testing</p>	Keywords	K1	1



Question Number (#)	Correct Answer	Explanation / Rationale	Learning Objective (LO)	K-Level	Number of Points
20	a	<p>The correct pairing of descriptions with the different categories of test techniques is:</p> <ul style="list-style-type: none"> <li>• Black-box test techniques</li> <li>• Deviations from the requirements are checked (4) User stories are used as the test basis (5)</li> <li>• White-box test techniques</li> <li>• Coverage is measured based on a selected structure of the test object (1) The processing within the test object is checked (2)</li> <li>• Experience-based test techniques</li> </ul> <p>Tests are based on defects' likelihood and their distribution (3)</p> <p>Thus, option a) is correct.</p>	FL-4.1.1	K2	1

Question Number (#)	Correct Answer	Explanation / Rationale	Learning Objective (LO)	K-Level	Number of Points
21	d	<p>The following valid equivalence partitions can be identified:</p> <ol style="list-style-type: none"> <li>1. Up to 1000 - Couch Potato!</li> <li>2. Above 1000, up to 2000 - Lazy Bones!</li> <li>3. Above 2000, up to 4000 - Getting There!</li> <li>4. Above 4000, up to 6000 - Not Bad!</li> <li>5. Above 6000 - Way to Go!</li> </ol> <p>The sets of test inputs therefore cover the following partitions:</p> <ol style="list-style-type: none"> <li>a) 0 (1), 1000 (1), 2000 (2), 3000 (3), 4000 (3) – 3 partitions (out of 5)</li> <li>b) 1000 (1), 2001 (3), 4000 (3), 4001 (4), 6000 (4) – 3 partitions (out of 5)</li> <li>c) 123 (1), 2345 (3), 3456 (3), 4567 (4), 5678 (4) – 3 partitions (out of 5)</li> <li>d) 666 (1), 999 (1), 2222 (3), 5555 (4), 6666 (5) – 4 partitions (out of 5)</li> </ol> <p>Thus, option d) is correct.</p>	FL-4.2.1	K3	1

Question Number (#)	Correct Answer	Explanation / Rationale	Learning Objective (LO)	K-Level	Number of Points									
22	b	<p>The following valid input equivalence partitions can be identified:</p> <ul style="list-style-type: none"> <li>• Hours                             <ol style="list-style-type: none"> <li>1. below 3 hours</li> <li>2. 3 to 6 hours</li> <li>3. above 6 hours</li> </ol> </li> <li>• Intensity                             <ol style="list-style-type: none"> <li>4. very low</li> <li>5. low</li> <li>6. medium</li> <li>7. high</li> </ol> </li> </ul> <p>The given test cases cover the following valid input equivalence partitions:</p> <table border="0" style="margin-left: 20px;"> <tr> <td>T1</td> <td>1.5 (1)</td> <td>Very low (4)</td> </tr> <tr> <td>T2</td> <td>7.0 (3)</td> <td>Medium (6)</td> </tr> <tr> <td>T3</td> <td>0.5 (1)</td> <td>Very low (4)</td> </tr> </table> <p>Thus, the missing valid input equivalence partitions are: (2), (5) and (7). These can be covered by two test cases, as (2) can be combined with either (5) or (7).</p> <p>Thus, option b) is correct.</p>	T1	1.5 (1)	Very low (4)	T2	7.0 (3)	Medium (6)	T3	0.5 (1)	Very low (4)	FL-4.2.1	K3	1
T1	1.5 (1)	Very low (4)												
T2	7.0 (3)	Medium (6)												
T3	0.5 (1)	Very low (4)												

Question Number (#)	Correct Answer	Explanation / Rationale	Learning Objective (LO)	K-Level	Number of Points																																	
23	c	<p>For the input equivalence partitions given, the above used boundary value technique yields the following 8 coverage items:                      10°C, 11°C, 15°C, 16°C, 19°C, 20°C, 22°C, 23°C.</p> <p>Hence, the options have the following boundary value coverage:</p> <ul style="list-style-type: none"> <li>a) 4 out of 8 (11, 20, 22 and 23).</li> <li>b) 3 out of 8 (15, 19 and 23).</li> <li>c) 5 out of 8 (10, 16, 19, 22 and 23).</li> <li>d) 3 out of 8 (15, 19 and 22)</li> </ul> <p>Thus, option c) is correct.</p>	FL-4.2.2	K3	1																																	
24	c	<p>The complete decision table is shown below:</p> <table border="1" style="margin-left: auto; margin-right: auto;"> <thead> <tr> <th colspan="2"></th> <th>Rules</th> <th>R1</th> <th>R2</th> <th>R3</th> <th>R4</th> </tr> </thead> <tbody> <tr> <td rowspan="2">Inputs</td> <td>Speed &gt; 50</td> <td></td> <td>T</td> <td>T</td> <td>F</td> <td>F</td> </tr> <tr> <td>School Zone</td> <td></td> <td>T</td> <td>F</td> <td>T</td> <td>F</td> </tr> <tr> <td rowspan="2">Outputs</td> <td>\$250 Fine</td> <td></td> <td>F</td> <td>T</td> <td>F</td> <td>F</td> </tr> <tr> <td>Driving license withdrawal</td> <td></td> <td>T</td> <td>F</td> <td>F</td> <td>F</td> </tr> </tbody> </table> <p>To achieve full coverage, test cases covering rules 2 and 3 are needed. DT4 satisfies the constraints of rule 2, while DT2 satisfies the constraints of rule 3.</p> <p>Thus, option c) is correct.</p>			Rules	R1	R2	R3	R4	Inputs	Speed > 50		T	T	F	F	School Zone		T	F	T	F	Outputs	\$250 Fine		F	T	F	F	Driving license withdrawal		T	F	F	F	FL-4.2.3	K3	1
		Rules	R1	R2	R3	R4																																
Inputs	Speed > 50		T	T	F	F																																
	School Zone		T	F	T	F																																
Outputs	\$250 Fine		F	T	F	F																																
	Driving license withdrawal		T	F	F	F																																

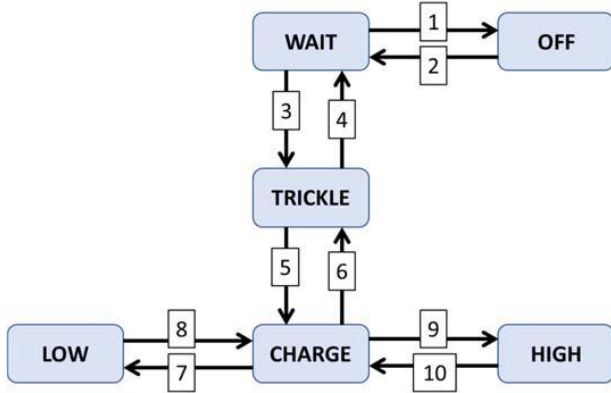
Question Number (#)	Correct Answer	Explanation / Rationale	Learning Objective (LO)	K-Level	Number of Points
25	d	<p>Given the annotated state model below:</p>  <pre>             graph TD                 WAIT -- 1 --&gt; OFF                 OFF -- 2 --&gt; WAIT                 WAIT -- 3 --&gt; TRICKLE                 TRICKLE -- 4 --&gt; WAIT                 TRICKLE -- 5 --&gt; CHARGE                 CHARGE -- 6 --&gt; TRICKLE                 CHARGE -- 7 --&gt; LOW                 LOW -- 8 --&gt; CHARGE                 CHARGE -- 9 --&gt; HIGH                 HIGH -- 10 --&gt; CHARGE             </pre> <p>The options achieve the following transition coverage:</p> <ul style="list-style-type: none"> <li>a) OFF (2) WAIT (1) OFF (2) WAIT (3) TRICKLE (5) CHARGE (9) HIGH (10) CHARGE (7) LOW = 7 transitions (out of 10)</li> <li>b) WAIT (3) TRICKLE (4) WAIT (1) OFF (2) WAIT (3) TRICKLE (5) CHARGE (7) LOW (8) CHARGE = 7 transitions (out of 10)</li> <li>c) HIGH (10) CHARGE (7) LOW (8) CHARGE (6) TRICKLE (4) WAIT (3) TRICKLE (4) WAIT (3) TRICKLE (5) = 7 transitions (out of 10)</li> <li>d) WAIT (3) TRICKLE (5) CHARGE (9) HIGH (10) CHARGE (6) TRICKLE (4) WAIT (1) OFF (2) WAIT = 8 transitions (out of 10)</li> </ul> <p>Thus, option d) is correct.</p>	FL-4.2.4	K3	1

Question Number (#)	Correct Answer	Explanation / Rationale	Learning Objective (LO)	K-Level	Number of Points
26	a	<p>a) Is correct. This explains that each use case specifies some behavior that a subject can perform in collaboration with one or more actors. It also (later) explains that tests are designed to exercise the defined behaviors (basic, exceptional and errors)</p> <p>b) Is not correct. Use cases normally specify requirements, and so do not 'include' the components that will implement them</p> <p>c) Is not correct. Tests based on use cases do exercise interactions between the actor and the system, but they are focused on the functionality and do not consider the ease of use of user interfaces</p> <p>d) Is not correct. Tests do cover the use case paths through the use case, but there is no concept of decision coverage of these paths, and certainly not of business process flows</p>	FL-4.2.5	K2	1
27	b	<p>a) Is not correct. Statement coverage is a measure of the proportion of executable statements exercised by tests. The number of executable statements is often close to the number of lines of code minus the comments, but this option only talks about the number of lines of code exercised and not the proportion exercised</p> <p>b) Is correct. Statement coverage is a measure of the proportion of executable statements exercised by tests (normally presented as a percentage)</p> <p>c) Is not correct. Statement coverage is a measure of the percentage of executable statements exercised by tests, however many of the lines of source code are not executable (e.g. comments)</p> <p>d) Is not correct. Statement coverage is a measure of the proportion of executable statements exercised by tests. This option only talks about the number of executable statements exercised and not the proportion (or percentage) exercised</p>	FL-4.3.1	K2	1

Question Number (#)	Correct Answer	Explanation / Rationale	Learning Objective (LO)	K-Level	Number of Points
28	d	<p>a) Is not correct. A path through source code is one potential route through the code from the entry point to the exit point that could exercise a range of decision outcomes. Two different paths may exercise all but one of the same decision outcomes, and by just changing a single decision outcome a new path is followed. Test cases that would achieve decision coverage are typically a tiny subset of the test cases that would achieve path coverage. In practice, most non-trivial programs (and all programs with unconstrained loops, such as 'while' loops) have a potentially infinite number of possible paths through them and so measuring the percentage covered is practically infeasible</p> <p>b) Is not correct. Coverage of business flows can be a focus of use case testing, but use cases rarely cover a single component. It may be possible to cover the decisions within business flows, but only if they were specified in enough detail, however this option only suggests coverage of "business flows" as a whole. Even if business flows would cover some decisions, the measure "Decision Coverage" don't measure the percentage of business flows, but the percentage of decision outcomes exercised by the business flows</p> <p>c) Is not correct. Achieving full decision coverage does require all 'if' statements to be exercised with both true and false outcomes, however, there are typically several other decision points in the code (e.g. 'case' statements and the code controlling loops) that also need to be taken into consideration when measuring decision coverage</p> <p>d) Is correct. Decision coverage is a measure of the proportion of decision outcomes exercised (normally presented as a percentage)</p>	FL-4.3.2	K2	1

Question Number (#)	Correct Answer	Explanation / Rationale	Learning Objective (LO)	K-Level	Number of Points
29	c	a) Is not correct. error guessing is not a usability technique for guessing how users may fail to interact with the test object b) Is not correct. Although a tester who used to be a developer may use their personal experience to help them when performing error guessing, the technique is not based on prior knowledge of development c) Is correct. The basic concept behind error guessing is that the tester tries to guess what mistakes may have been made by the developer and what defects may be in the test object based on past-experience (and sometimes checklists) d) Is not correct. Duplicating the development task has several flaws that make it impractical, such as the requirement for the tester to have equivalent skills to the developer and the time involved in performing the development. It is not error guessing	FL-4.4.1	K2	1
30	d	a) Is not correct. Quality should be the responsibility of everyone working on the project and not the sole responsibility of the test team b) Is not correct. First, it is not a benefit if an external test team does not meet delivery deadlines, and second, there is no reason to believe that external test teams will feel they do not have to meet strict delivery deadlines c) Is not correct. It is bad practice for the test team to work in complete isolation, and we would expect an external test team to be concerned with changing project requirements and communicate well with developers d) Is correct. Specifications are never perfect, meaning that assumptions will have to be made by the developer. An independent tester is useful in that they can challenge and verify the assumptions and subsequent interpretation made by the developer	FL-5.1.1	K2	1



Question Number (#)	Correct Answer	Explanation / Rationale	Learning Objective (LO)	K-Level	Number of Points
31	a	a) Is correct. One of the typical tasks of a test manager b) Is not correct. One of the typical tasks of a tester c) Is not correct. One of the typical tasks of a tester d) Is not correct. One of the typical tasks of a tester	FL-5.1.2	K1	1
32	d	The correct pairings of examples to entry and exit criteria are: <ul style="list-style-type: none"> <li>• Entry criteria                             <ul style="list-style-type: none"> <li>○ (3) The trading performance test environment has been designed, set-up and verified – example of the need for a test environment to be ready before testing can begin</li> <li>○ (5) The autopilot design specifications have been reviewed and reworked – example of the need for the test basis to be available before testing can begin</li> <li>○ (6) The tax rate calculation component has passed unit testing – example of the need for a test object to have met the exit criteria for a prior level of testing before testing can begin</li> </ul> </li> <li>• Exit criteria                             <ul style="list-style-type: none"> <li>○ (1) The original testing budget of \$30,000 plus contingency of \$7,000 has been spent – example of spending the testing budget being a signal to stop testing</li> <li>○ (2) 96% of planned tests for the drawing package have been executed and the remaining tests are now out of scope – example of all the planned tests being run being a signal to stop testing (normally used alongside the exit criteria on outstanding defects remaining)</li> <li>○ (4) Current status is no outstanding critical defects and two high-priority ones – example of the number of outstanding defects achieving a planned limit being a signal to stop testing (normally used alongside the exit criteria on planned tests being run).</li> </ul> </li> </ul> Thus, option d) is correct.	FL-5.2.3	K2	1

Question Number (#)	Correct Answer	Explanation / Rationale	Learning Objective (LO)	K-Level	Number of Points
33	b	<p>The test cases should be scheduled in priority order, but the schedule must also take account of the dependencies.</p> <p>The two highest priority test cases (TC1 and TC3) are both dependent on TC4, so the first three test cases should be scheduled as either TC4 – TC1 – TC3 or TC4 – TC3 – TC1 (we have no way to discriminate between TC1 and TC3).</p> <p>Next, we need to consider the remaining medium priority test case, TC6. TC6 is dependent on TC5, but TC5 is dependent on TC2, so the next two three cases must be scheduled as TC2 – TC5 – TC6.</p> <p>This means there are two possible optimal schedules:</p> <ul style="list-style-type: none"> <li>• TC4 – TC1 – TC3 – TC2 – TC5 – TC6 or</li> <li>• TC4 – TC3 – TC1 – TC2 – TC5 – TC6</li> </ul> <p>Thus, option b) is correct.</p>	FL-5.2.4	K3	1
34	c	<p>a) Is not correct. Estimates may be updated as more information becomes available, but estimates are needed to assist with planning before the testing starts</p> <p>b) Is not correct. In the expert-based approach, the experts need to be experts in testing, not in using the test object</p> <p>c) Is correct. Test -Managers, who will be leading testers doing the testing, are considered experts in their respective areas and suitable for estimating the necessary resources needed</p> <p>d) Is not correct. While it is useful to know the testing costs from previous projects, a more sophisticated approach is needed than simply taking an average of past projects (the new project may not be like the previous projects, e.g. it may be far larger or far smaller than previous projects)</p>	FL-5.2.6	K2	1

Question Number (#)	Correct Answer	Explanation / Rationale	Learning Objective (LO)	K-Level	Number of Points
35	c	a) Is not correct. Risk is determined by considering a combination of the likelihood of problem situations and the harm that may result from them but cannot be calculated by adding these together (the probability would be in the range 0 to 1 and the harm could be in dollars) b) Is not correct. Risk is determined by considering a combination of a likelihood and an impact. This definition only considers likelihood and chance (both forms of probability) with no consideration of the impact (or harm) c) Is correct. See reasons from incorrect answers d) Is not correct. Risk is determined by considering a combination of a likelihood and an impact. This definition only considers hazards and losses (a hazard is a bad event, like a risk, while loss is a form of impact) with no consideration of the likelihood (or probability)	FL-5.5.1	K1	1
36	a	a) Is correct. If the expected security features are not supported by the system architecture, then the system could be seriously flawed. As the system being produced is the problem here, it is a product risk b) Is not correct. If the developers run over budget, or run out of time, that is a problem with the running of the project – it is a project risk c) Is not correct. If the test cases do not provide full coverage of the requirements, this means the testing may not fulfil the requirements of the test plan – it is a project risk d) Is not correct. If the test environment is not ready, this means the testing may not be done, or it may have to be done on a different environment and it is impacting how the project is run – it is a project risk	FL-5.5.2	K2	1

Question Number (#)	Correct Answer	Explanation / Rationale	Learning Objective (LO)	K-Level	Number of Points
37	b	<p>a) Is not correct. As we are told security flaws have a particularly high impact, their risk level will be higher, and thus we have prioritized the security testing ahead of some other testing. Thus, product risk analysis has influenced the testing</p> <p>b) Is correct. As less defects than expected have been found in the network module, the perceived risk in this area should be lower, and so less testing should be focused on this area, NOT additional testing. Thus, product risk analysis has NOT CORRECTLY influenced the testing in this situation</p> <p>c) Is not correct. Because the users had problems with the user interface of the previous system, there is now high awareness of the risk associated with the user interface, which has resulted in additional usability testing being planned. Thus, product risk analysis has influenced the thoroughness and scope of testing</p> <p>d) Is not correct. As the time needed to load web pages has been identified as crucial to the success of the new website, the performance of the website should be considered a risk, and the employment of an expert in performance testing helps to mitigate this risk. Thus, product risk analysis has influenced the testing</p>	FL-5.5.3	K2	1

Question Number (#)	Correct Answer	Explanation / Rationale	Learning Objective (LO)	K-Level	Number of Points
38	d	<p>Considering each of the pieces of information:</p> <ol style="list-style-type: none"> <li>1. Degree of impact (severity) of the defect – the developers are already aware of the problem and are waiting to fix it, so this is a less important piece of information.</li> <li>2. Identification of the test item – as the developers are already aware of the problem and you are performing system testing, and you have already provided the version of the system you are testing you can assume they know the item that was being tested, so this is a less important piece of information.</li> <li>3. Details of the test environment – the set-up of the test environment may have a noticeable effect on the test results, and detailed information should be provided, so this is an important piece of information.</li> <li>4. Urgency/priority to fix – the developers are already aware of the problem and are waiting to fix it, so this is a less important piece of information.</li> <li>5. Actual results – the actual results may well help the developers to determine what is going wrong with the system, so this is an important piece of information.</li> <li>6. Reference to test case specification – this will show the developers the tests you ran, including the test inputs that caused the system to fail (and expected results), so this is an important piece of information.</li> </ol> <p>Thus, option d) is correct.</p>	FL-5.6.1	K3	1

Question Number (#)	Correct Answer	Explanation / Rationale	Learning Objective (LO)	K-Level	Number of Points
39	c	The correct pairings of test activities and test tools are: <ol style="list-style-type: none"> <li>1. Performance measurement and dynamic analysis – (b) Dynamic analysis tools</li> <li>2. Test execution and logging – (a) Requirements coverage tools</li> <li>3. Management of testing and testware – (d) Defect management tools</li> <li>4. Test design – (c) Test data preparation tools</li> </ol> Thus, option c) is correct.	FL-6.1.1	K2	1
40	a	<ol style="list-style-type: none"> <li>a) Is correct</li> <li>b) Is not correct. The evaluation of the test automation skills and training, mentoring and coaching needs of the testers who will use the tool should have been performed as part of the tool selection activity</li> <li>c) Is not correct. The decision on whether the tool provides the required functionality and does not duplicate existing tools should have been performed as part of the tool selection activity</li> <li>d) Is not correct. The evaluation of the tool vendor in terms of the training and other support they provide should have been performed as part of the tool selection activity</li> </ol>	FL-6.2.2	K1	1